

JETX

Perfect. Blasting Performance



We Make
surfaces
Perfect.



Model: 45 Suction

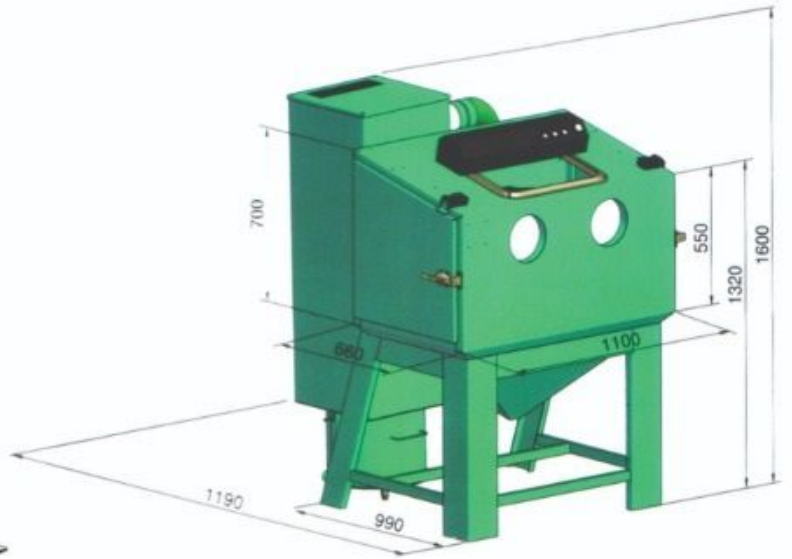

Model: 25 Suction

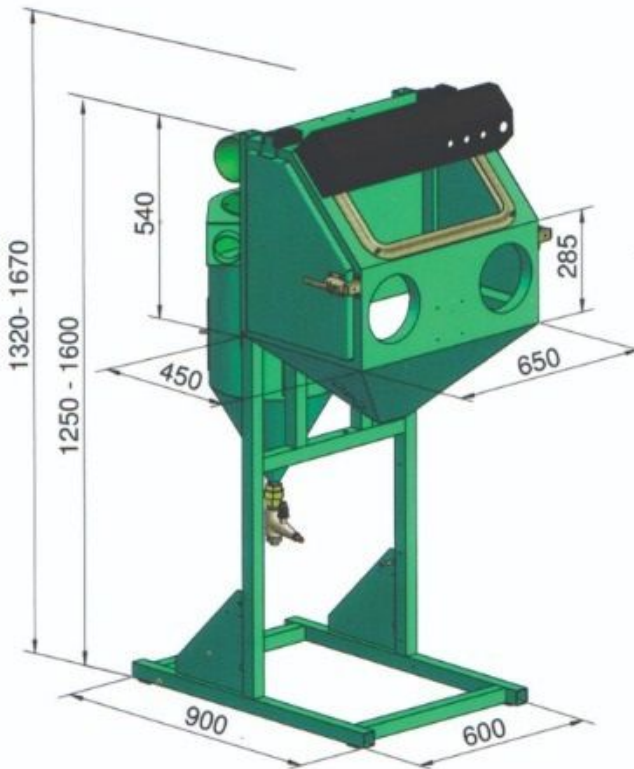

Model: 100 Suction/Pressure Blasting

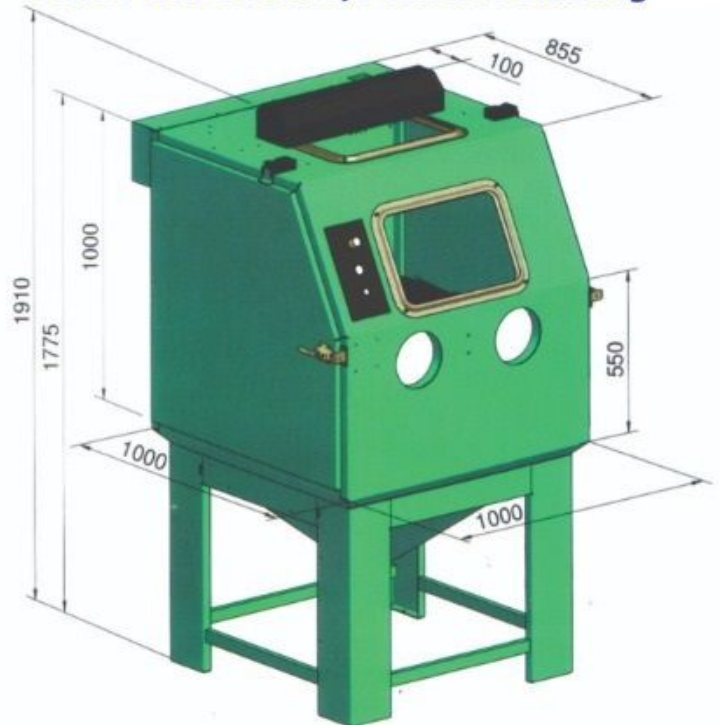

Model: JetX 160 Pressure Blasting Cabinet

Model:

160 – 1703 (2.2 kW)

Reclaim system type 255

Cartridge filter with automatic dedusting.

Working area

Width: 1350 mm

Depth: 1100 mm

Height: 570 to 1100 mm

Blasting space

Dustproof vacuum cabinet in a stable steel sheet design.

Doors

2 side doors with dustproof closures, double-walled and foam-filled for sound absorption, lockable, with emergency shut-down.

Reclaim system

The reclaim system adapted specifically to the cabinet guarantees continuous processing of the blast medium through the constant separation of impurities, dust and pulverized grit. A magnetic separator isolates ferritic particles.



Advantages

High, stable blasting performance, reproducible surface quality, economic grit consumption, optimum blasting performance at all pressures.

with additional fittings:
turntable with loading platform, load capacity:
Pressure blasting system clad with highly wear-resistant firm rubber.

Blasting Cabinet

Model: JetX 160 Suction/Pressure Blasting

Working gloves

Made of special rubber, wear-resistant, anti-static, cotton lining, fixed to the cabinet.

Operating controls

On/off switch for blasting space illumination and reclaim, effective compressed air utilization thanks to the Air Logic system. Foot pedal, master valve incl. oil and condensate separator, pressure regulator and manometer.

Window

320 x 500 mm safety glass, easy to replace without special tools.

Blasting space illumination

Externally mounted, very good illumination through halogen spotlights.

Blow-off nozzle

Air nozzle for cleaning the blasted workpieces.

blasting gun

system, high-performance blasting gun with optimum efficiency, operation via foot pedal, can be supplied with various nozzle sizes/materials.

pressure blasting system

Can be supplied with various vessel sizes – 100 or 200 l, including built-on blast medium reclaim system.

power-safe system

Significantly reduces power consumption.

Air consumption

Blasting nozzle diameter	Air requirements at 6 bar l/min – suction	Air requirements at 6 bar l/min – pressure blasting
4.8 mm	—	1100
6.5 mm	590	2100
8.0 mm	910 standard	3200
10.0 mm	1340	—



a compact machine with integrated cartridge filter and blast medium reclaim system.

Blasting Cabinet

Model: 160 Suction/Pressure Blasting



Model: 300 - Mini Blast Room

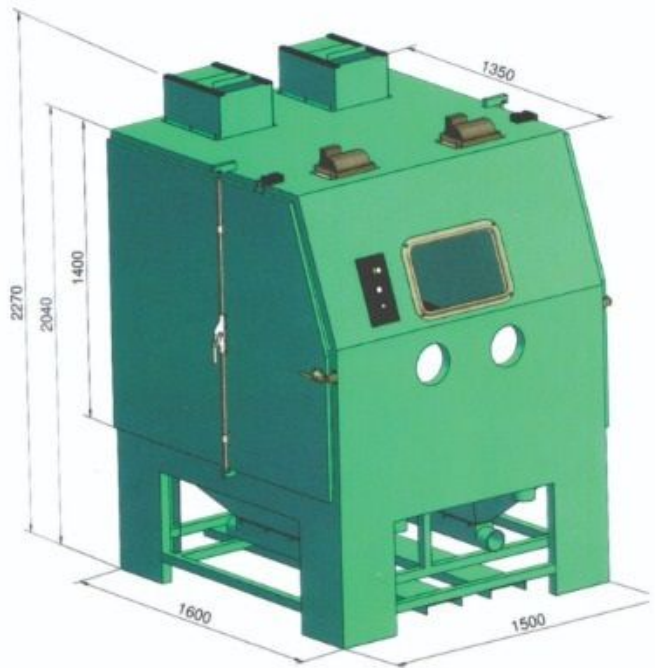

Model: 500 - Mini Blast Room

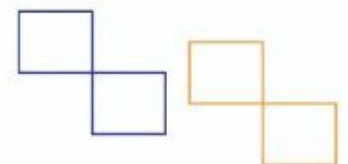
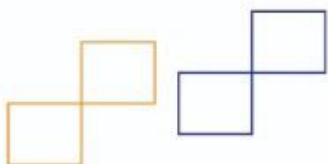
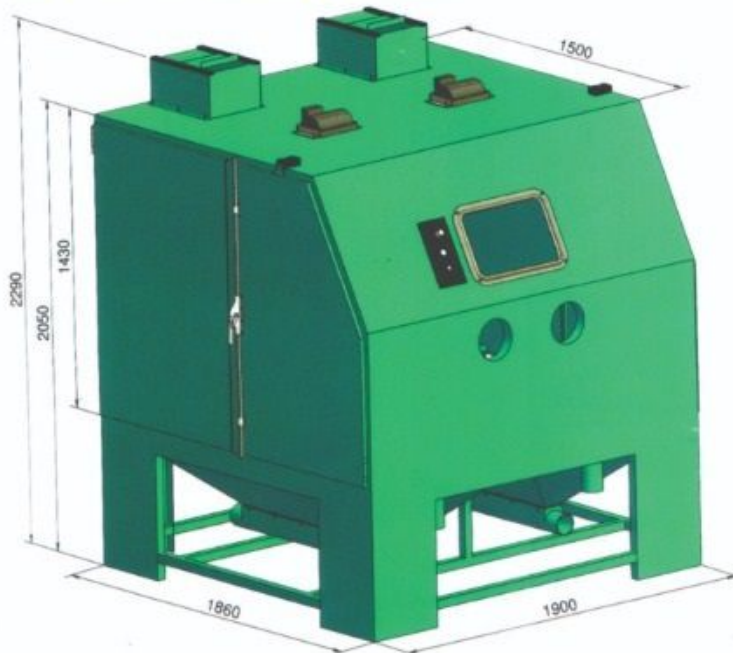

Model: 45K Suction

Working gloves

Made of special rubber, wear-resistant, anti-static, cotton lining, fixed to the cabinet.

Operating controls

On/off switch for blasting space illumination and reclaim, effective compressed air utilization thanks to the Air Logic system. Foot pedal, master valve incl. oil and condensate separator, pressure regulator and manometer.

Window

320 x 500 mm safety glass, easy to replace without special tools.

Blasting space illumination

Externally mounted, very good illumination through fluorescent strip lighting.

Blow-off nozzle

Air nozzle for cleaning the blasted workpieces.

blasting gun

system, operation via foot pedal, can be supplied with various nozzle sizes/materials.

Air consumption

Blasting nozzle diameter	Air requirements at 6 bar l/min
--------------------------	---------------------------------

6.5 mm	590
8.0 mm	910 standard
10.0 mm	1340



Rear View: Model SKAT 45K

Blasting Cabinet

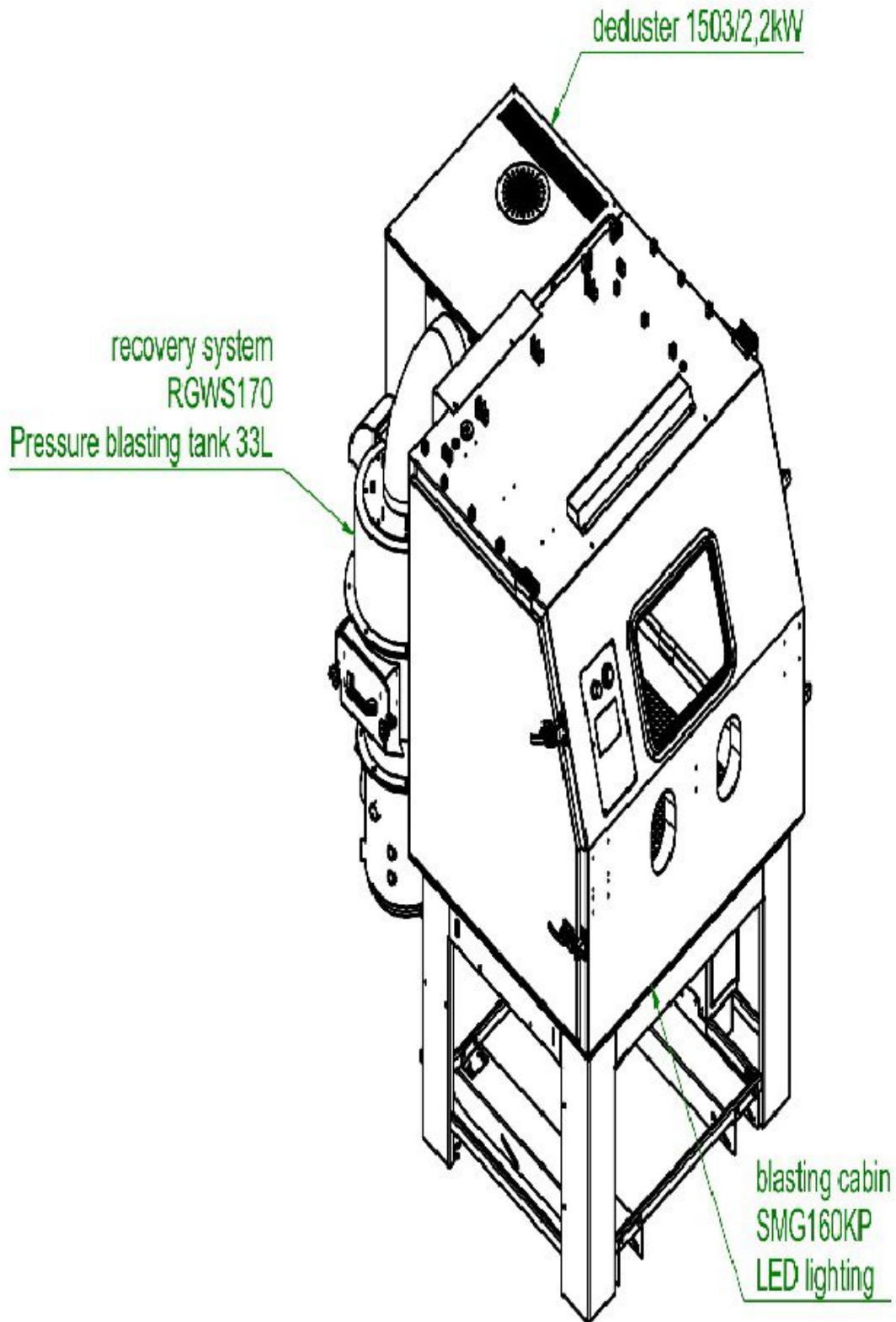

Blasting Cabinet